



COIN COMPARITOR



MODEL
CC-16

Approved by
D.G.E. &
G.L.I.



- CM Comparitor® products are the gaming industries' choice around the world
- Proven reliable under extreme gaming conditions
- CC-16 product offered in voltages ranging from 12 volts DC to 55 volts AC
- CC-16 designed for coin diameters of .700" (17.8mm) thru 1.478" (37.5mm) (Wide Body model recommended for coin diameters up to 1.950" (49.5mm))
- The CC-16 is the most widely used and recognized gaming coin validator
- Coin feed performance rated at 7 coins-per-second
- Patented magnetic induction system provides an accept/reject decision within milliseconds, defining speed, security and reliability
- Straight drop coin path
- Optional inhibit feature



COIN MECHANISMS INC. *Where The Money Meets The Machine*

P.O. Box 5128, 400 Regency Drive, Glendale Heights, IL 60139-5128
630/924-7070 • 1-800/323-6498 (In USA & Canada) • FAX 630/924-7088
www.coinmech.com

COIN COMPARITOR[®]

MODEL CC-16 SPECIFICATIONS

Multi-Voltage Models

ELECTRICAL

POWER REQUIREMENTS

PIN 6 GROUND	all CC-16 Comparitors			
PIN 5 INPUT VOLTAGE	VAC 50/60 Hz min.	VAC 50/60 Hz max.	VDC min.	VDC max.
Voltage Range	15	21	15	26
Idle mA (typical)	75	200	20	66
Peak mA (typical)	200	375	96	196

Note: For 12 VAC operation change R41 to 360 k ohms

PIN 4 INPUT VOLTAGE	VAC 50/60 Hz min.	VAC 50/60 Hz max.	VDC min.	VDC max.
Voltage Range	22	37	16	32
Idle mA (typical)	55	114	20	69
Peak mA (typical)	87	158	64	146

PIN 3 INPUT VOLTAGE	VAC 50/60 Hz min.	VAC 50/60 Hz max.	VDC min.	VDC max.
Voltage Range	42	55	19.5	42
Idle mA (typical)	63	99	23	69
Peak mA (typical)	79	119	53	112

OUTPUT

PIN 2 SENSE OUTPUT	Pulse output type	Output Volts	Current mA max.	Pulsewidths ms (coin dia. dependent)
	Sourcing (active high)	V _{in}	100	12-21 (typical)

PIN 1 not used

MECHANICAL

See Dimensioned Drawing For Mounting Specifications

COIN SPECIFICATIONS	DIAMETER in/mm	THICKNESS in/mm	WEIGHT g.
MIN.	.700/17.78	.055/1.4	4.4
MAX.	1.478/37.54	.130/3.30	25

Note: Coin diameter and thickness range is accomplished with part variations.

ENVIRONMENTAL*

Operating temp: 0 to 60 deg C
 Storage temp: -40 to 80 deg C
 EMI Rejection: Operates reliably within a 1 MHz to 1 GHz field to 50V/meter

PERFORMANCE*

FEED RATE: 7 coins/sec. > 98% valid coin acceptance.
 *All testing is based on U.S. quarter as test coin, with adjustment set to accept all quarters and reject copper slugs. Coins are dropped from a maximum height of 2" above insert with coins vertically oriented and aligned with the coin insert opening. Nominal operating voltage.

COIN COMPARITOR[®]

MODEL CC-16 SPECIFICATIONS

12 and 13 VDC Models Only

ELECTRICAL

POWER REQUIREMENTS

PIN 6 GROUND	all CC-16 Comparitors			
PIN 5	Vin	OPERATING VOLTAGE	VDC min.	VDC max.
Voltage Range 12VDC Model (regulated)			11.5	12.5
Voltage Range 13VDC Model (regulated)			11	15
Idle mA (typical)			75	75
Peak mA (typical)			250	250

PIN 4 and PIN 3 not used

I/O

PIN 2 SENSE OUTPUT	Output Type	Output Volts	ImA	PULSEWIDTH (typ.)
12 Volt Model	Sourcing (active high)	Vin	100	12-21ms
13 Volt Model	Open Collector (active low)		100	12-21 ms

PIN 1 INHIBIT CONTROL *	Enable	Inhibit		
12 Volt Model	Ground or <0.7VDC	Open or >5.0VDC		
13 Volt Model	Ground or <0.5VDC	Open or >1.5VDC		

PINOUT J3

1	2	3	4	5	6
Inhibit	Sense Output	not used	not used	Vin 12/13VDC	Ground

MECHANICAL

COIN SPECIFICATIONS	DIAMETER in/mm	THICKNESS in/mm	WEIGHT g.
MIN.	.700/17.78	.055/1.27	2.2
MAX.	1.478/37.54	.130/3.30	25

Note: Coin diameter and thickness range is accomplished with part variations.

*The optional INHIBIT feature allows the mechanism to be disabled (no coin acceptance) without removing power from the mechanism. Grounding PIN 1 allows the accept coil armature to operate normally when valid coins are sensed. Floating or applying a voltage > 5.0VDC to PIN 1 will disable the accept coil armature and reject coins even though they may be sensed as good coins.

ENVIRONMENTAL *

Operating temp: 0 to 60 deg C
 Storage temp: -40 to 80 deg C
 EMI Rejection: Operates reliably within a 1 MHz to 1 GHz field to 50V/meter

PERFORMANCE*

FEED RATE: 7 coins/sec. > 98% valid coin acceptance.
 *All testing is based on U.S. quarter as test coin, with adjustment set to accept all quarters and reject copper slugs. Coins are dropped from a maximum height of 2" above insert with coins vertically oriented and aligned with the coin insert opening. Nominal operating voltage.

CC-16 25¢ U.S. Model (Typical Coin Size)

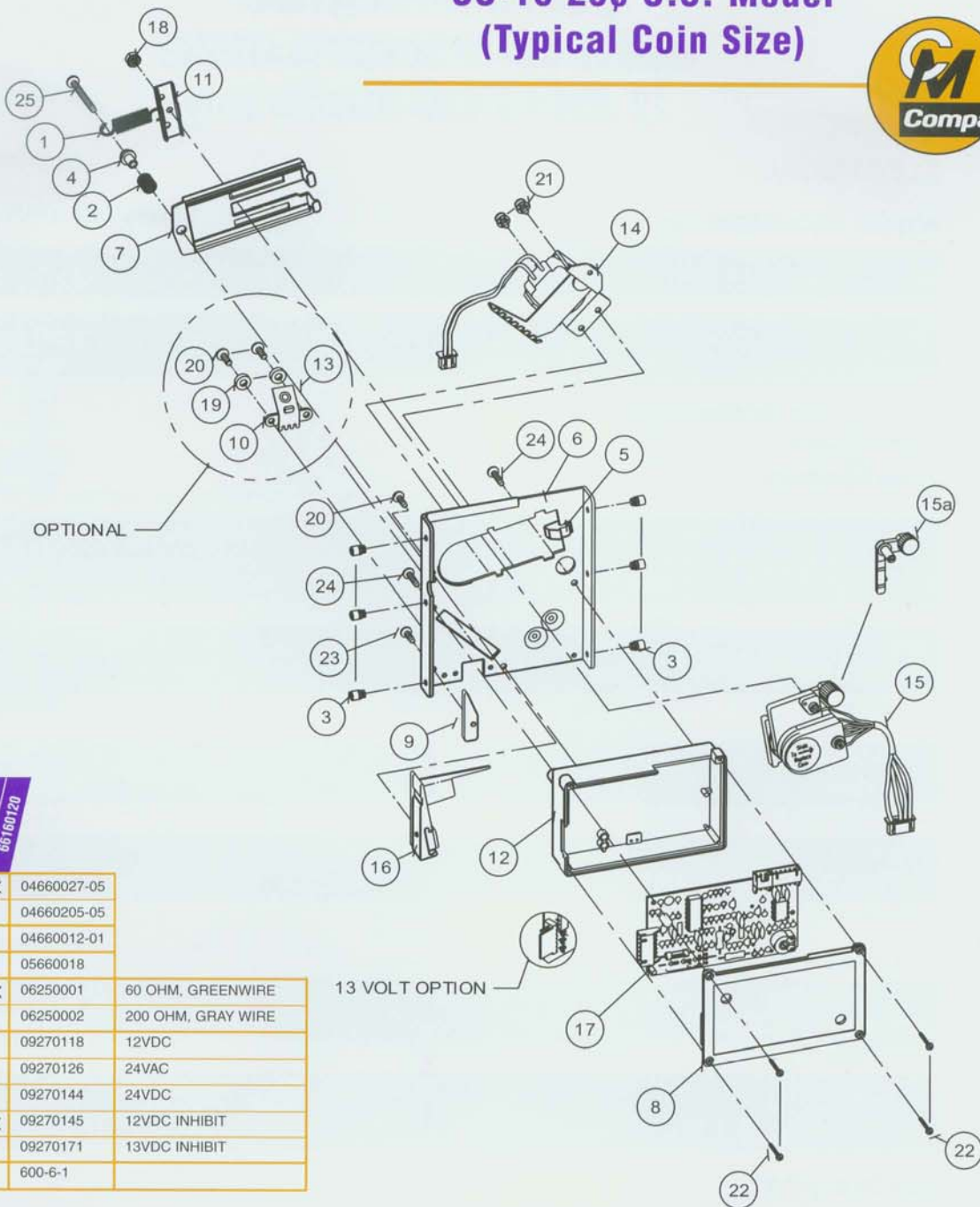

ITEM NO.
66160046
66160058
66160070
66160117
66160188
66160120

6	X	X	X		X	04660027-05	
				X	X	04660205-05	
10	X	X	X			04660012-01	
13	X	X	X			05660018	
14		X		X		06250001	60 OHM, GREEN WIRE
	X			X		06250002	200 OHM, GRAY WIRE
		X				09270118	12VDC
				X		09270126	24VAC
17	X	X				09270144	24VDC
				X		09270145	12VDC INHIBIT
			X			09270171	13VDC INHIBIT
19	X	X	X			600-6-1	

13 VOLT OPTION

MATERIAL COLUMN							
ITEM	P/N	QTY	MATL DESCRIPTION	ITEM	P/N	QTY	MATL DESCRIPTION
1	04050031	1	SPRING, EXTENSION, 1-1/16, COIL LOCKING	14	0625XXXX	1	COIL, & BRKT, ASSY
2	04050027	1	SPRING, COMPRESSION, COIL RETAINER	15	06250063	1	COIL, ASSY, SENSOR, CC16/40, 2.6G, 3" LDS, TERM
3	04060005-01	6	STUD, #6 MTG	15a	06660012	—	DAMPNER WEIGHT, ASSY, 2.6G, DBL NUT
4	04060052-01	1	BUSHING, SPRING RETAINING	16	06660038	1	RAIL, ASSY, SM RAIL, STD INSERT
5	04660002	1	STOP, SENSING COIL SAFETY	17	0927XXXX	1	PCB, CTRL
6	0466XXXX	1	MAINPLATE	18	436-4	1	NUT, 4-40, HEX, KEPS
7	04660030	1	SHIELD, SENSOR COIL RETAINING	19	600-6-1	2	WASHER, FLAT, DBL THICKNESS, #6
8	04660098	1	COVER, PCB	20	P-104-4-3	A/R	SCREW, 4-40 x 3/16, PHIL, PH, MS
9	046600113	1	SPACER, COIN EXIT, .110	21	P-186-4-3	2	SCREW, 4-40 x 3/16, PHIL, SEMS WASHER
10	04660012-01	1	RETAINER, ANTI-STRINGING LEVER	22	P-217-2-5	4	SCREW, 2 x 5/16, PHIL, PH, HI-LO
11	04660062-01	1	BRKT, COIL LOCKING	23	P-221-4-3	1	SCREW, 4 x 3/16, PHILTYPE 45, PLASTITE
12	05660017	1	HSG, ASSY, PCB, ELEVATED w/STEP	24	P-221-4-4	1	SCREW, 4 x 1/4, PHILTYPE 45, PLASTITE
13	05660018	1	LEVER, ANTI-STRINGING LEVER	25	P-221-4-12	1	SCREW, 4 x 3/4, PHILTYPE 45, PLASTITE

CC-16 25¢ U.S. Model (Typical Coin Size) Snap-On Housing Version

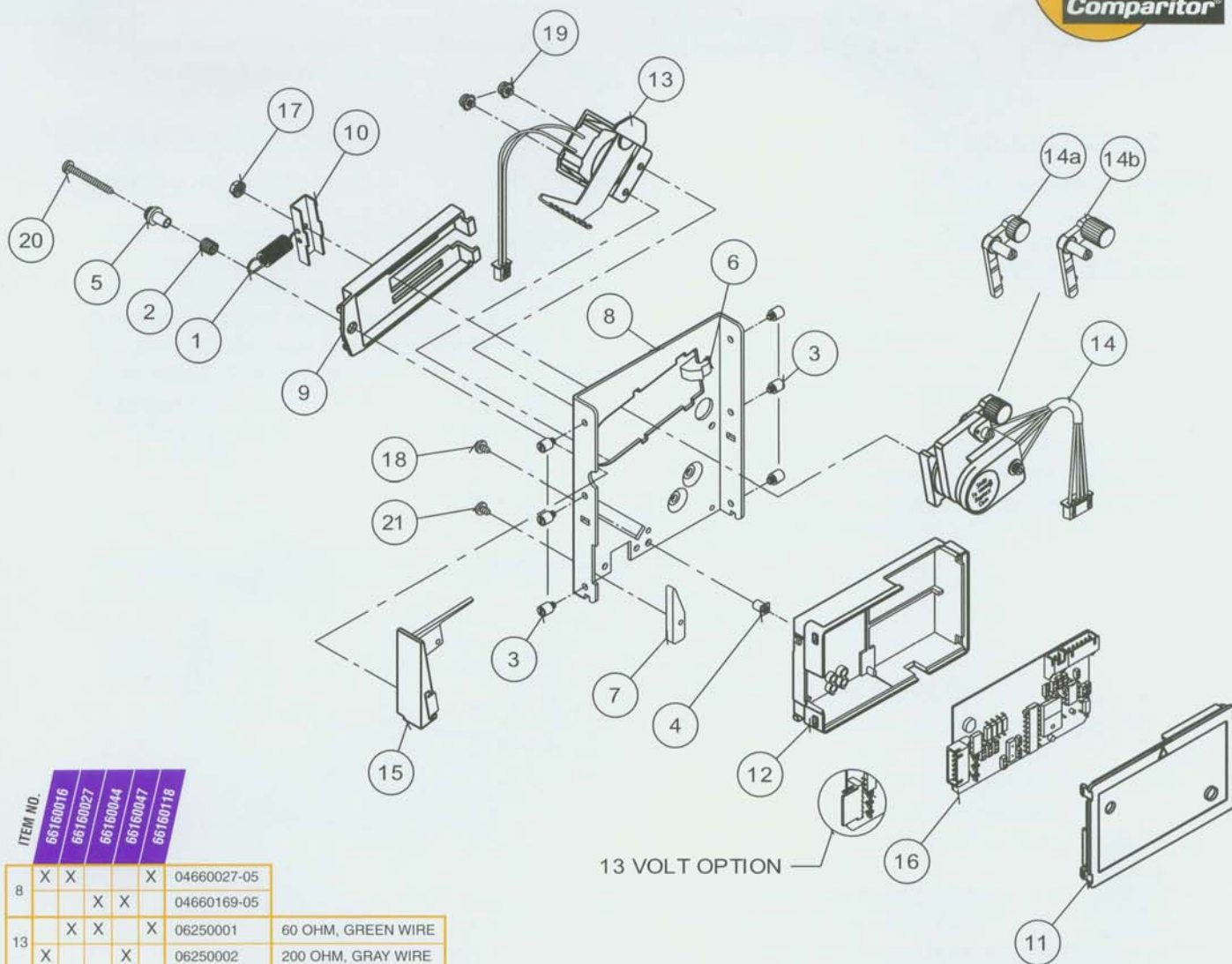

ITEM NO.	66160016	66160027	66160044	66160047	66160118	
8	X	X			X	04660027-05
			X	X		04660169-05
13		X	X		X	06250001 60 OHM, GREEN WIRE
	X			X		06250002 200 OHM, GRAY WIRE
14	X	X	X	X		06250063 2.6 GRAM WEIGHT
				X		06250112 6.0 GRAM WEIGHT
	X					09270118 12VDC
16	X			X		09270144 24VDC
		X		X		09270145 12VDC

MATERIAL COLUMN							
ITEM	P/N	QTY	MATL DESCRIPTION	ITEM	P/N	QTY	MATL DESCRIPTION
1	04050031	1	SPRING, EXTENSION, 1-1/16, COIL LOCKING	13	0625XXXX	1	COIL, & BRKT, ASSY
2	04050027	1	SPRING, COMPRESSION, COIL RETAINER	14	0625XXXX	1	COIL, ASSY, SENSOR
3	04060005-01	6	STUD, #6 MTG	14a	06660012	—	DAMPNER & WEIGHT, ASSY, 2.6G
4	04060036	1	INS, NUT, #4-40	14b	06660013	—	DAMPNER & WEIGHT, ASSY, 6.0G
5	04060052-01	1	BUSHING, SPRING RETAINING	15	06660038	1	RAIL, ASSY, SM RAIL, STD INSERT
6	04660002	1	STOP, SENSING COIL SAFETY	16	0927XXXX	1	PCB, CTRL
7	04660021	1	SPACER, COIN EXIT, .155	17	436-4	1	NUT, 4-40, HEX, KEPS
8	0466XXXX	1	MAINPLATE	18	P-104-4-3	1	SCREW, 4-40 x 3/16, PHIL, PH, MS
9	04660030	1	SHIELD, SENSOR COIL RETAINING	19	P-186-4-3	2	SCREW, 4-40 x 3/16, PHIL, SEMS WASH
10	04660062-01	1	BRKT, COIL LOCKING	20	P-221-4-12	1	SCREW, 4 x 3/4, PHILTYPE, 45, PLASTITE
11	04660165	1	COVER, PCB HSG, UNIVERSAL	21	P-221-4-3	1	SCREW, 4 x 3/16, PHILTYPE, 45, PLASTITE
12	04660166	1	HSG, PCB, UNIVERSAL				

CC-16 \$1 U.S. Token Model (Typical Coin Size)

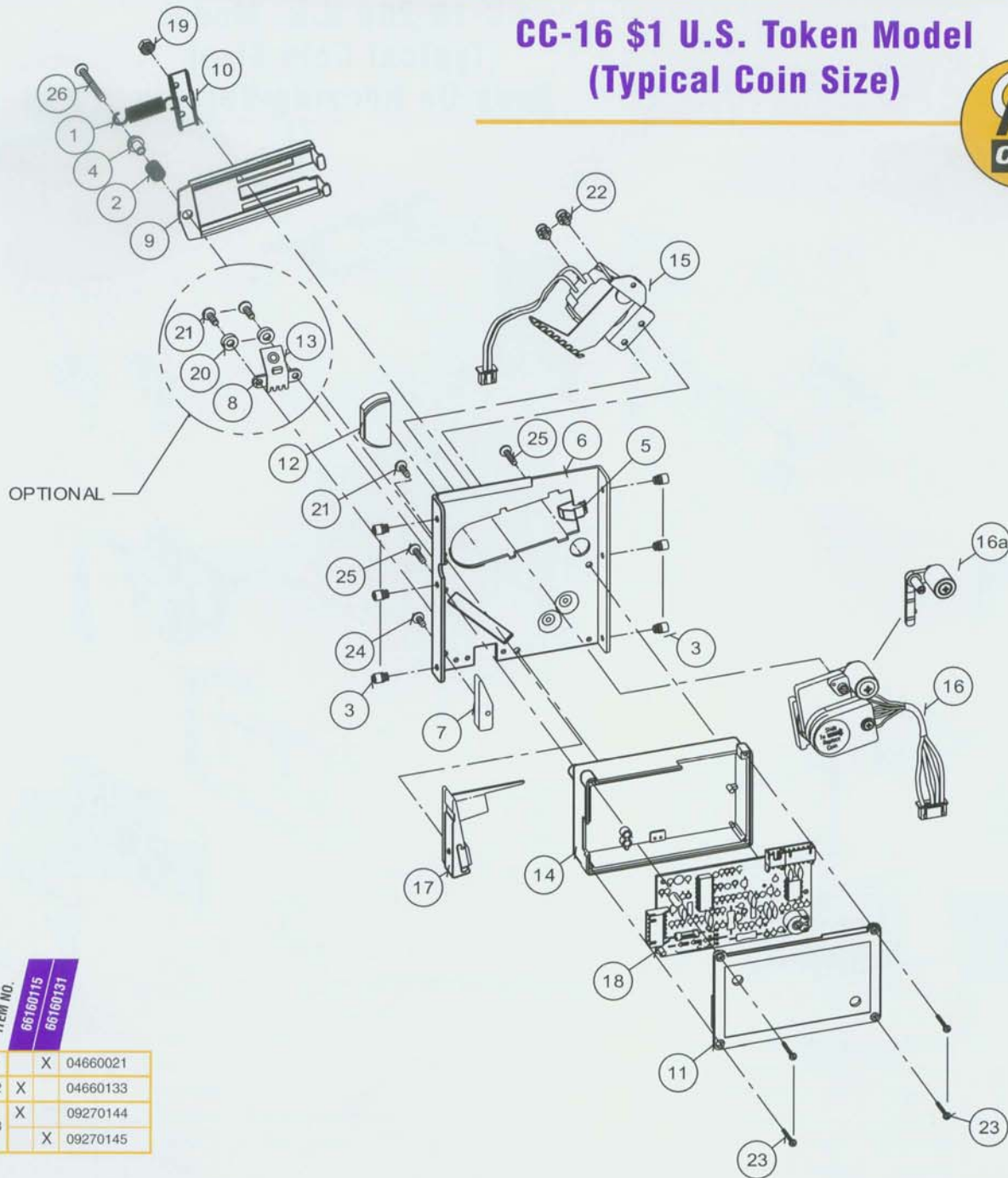

ITEM NO.
66160115
66160131

11	X	04660021
12	X	04660133
	X	09270144
18	X	09270145

MATERIAL COLUMN							
ITEM	P/N	QTY	MATL DESCRIPTION	ITEM	P/N	QTY	MATL DESCRIPTION
1	04050031	1	SPRING, EXTENSION, 1-1/16, COIL LOCKING	15	06250001	1	COIL & BRKT, ASSY, GRN, 4, 2PST, CC18-TYPE
2	04050027	1	SPRING, COMPRESSION, COIL RETAINING	16	06250089	1	COIL, ASSY, SENSOR, CC16, 14.2G, 3" LDS
3	04060005-01	6	STUD, #6 MTG	16a	06660014	—	DAMPNER WEIGHT, ASSY, 14.2G, DBL NUT
4	04060052-01	1	BUSHING, SPRING RETAINING	17	06660038	1	RAIL, ASSY, SM REIL, STD INSERT
5	04660002	1	STOP, SENSING COIL SAFETY	18	0927XXXX	1	PCB, CTRL
6	04660012-01	1	MAINPLATE, w/ANTI-CHEAT NOTCH	19	436-4	1	NUT, 4-40, HEX, KEPS
7	04660021	1	SPACER, COIN EXIT, .155	20	600-6-1	2	WASHER, FLAT DOUBLE THICKNESS, #6
8	04660027-05	1	RETAINER, ANTI-STRINGING LEVER	21	P-104-4-3	A/R	SCREW, 4-40 x 3/16, PHIL, PH, MS
9	04660030	1	SHIELD, SENSOR COIL RETAINING	22	P-186-4-3	2	SCREW, 4-40 x 3/16, PHIL, SEMS WASHER
10	04660062-05	1	BRKT, COIL LOCKING	23	P-217-2-5	4	SCREW, 2 x 5/16, PHIL, PH, HI-LO
11	04660098	1	COVER, PCB	24	P-221-4-3	1	SCREW, 4 x 3/16, PHILTYPE, 45, PLASTITE
12	04660133	1	SPACER, SENSOR COIL, 1.205 DIA.	25	P-221-4-4	2	SCREW, 4 x 1/4, PHILTYPE, 45, PLASTITE
13	05660018	—	LEVER, ASSY, ANTI-STRINGING	26	P-221-4-12	1	SCREW, 4 x 3/4, PHILTYPE, 45, PLASTITE
14	05660029	1	HSG, ASSY, PCB, .150, ELEVATED, NO STEP				

CC-16 OPERATING INSTRUCTIONS



Please determine proper operating voltage for the model you are installing

TURN POWER OFF

Installing the sample coin:

A Resident coin must be installed for proper operation. Looking at the front of the Comparitor, slide (without lifting) the sensor coil assembly to the right. Replace the sample coin or chip with the desired coin, and then carefully release. In most cases, the coin will automatically seat itself. When properly seated, the coin will rest parallel between the sensor coil assembly and between the ribs on the rail insert.

Wiring Instructions

See diagrams below for specific pinout details for the voltage being used.

12 Volt DC/24-55 Volt AC/DC Machine Interface

- 1- Inhibit (where applicable)
- 2- Sense Output
- 3- AC Voltage range: 42-55
DC Voltage range: 19.5-42
- 4- AC Voltage range: 22-37
DC Voltage range: 16-32
- 5- AC Voltage range: 15-21
DC Voltage range: 15-26
- *For 12 Volt specific models
DC Voltage range: 11.5-12.5
- 6- Ground

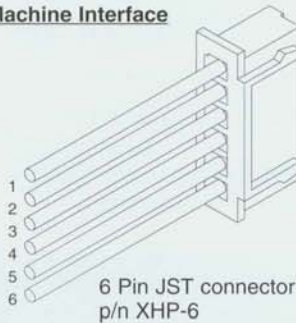

IGT 24 Volt AC Machine Interface

- 1- 4.7K OHM Resistor to Ground
- 2- Sense Output
- 3- Triac Load Jumper
- 4- 24 Volt
- 5- N/C
- 6- Ground

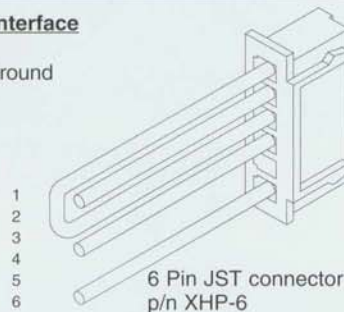

13 Volt DC Inhibit Machine Interface

- 6- Ground
- 5- 13VDC
- 4- N/C
- 3- N/C
- 2- Sense
- 1- Inhibit

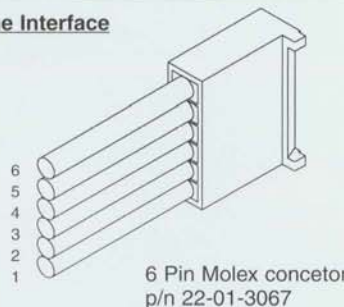

POTENTIOMETER ADJUSTMENT

Each Comparitor leaving the factory is adjusted to give excellent discrimination against slugs. However, some high quality slugs may need a finer adjustment. To do this follow these three easy steps:

1. Adjust potentiometer clockwise (CW) until high quality slug is rejected.
2. Drop good coins to ensure accurate acceptance.
3. Repeat steps 1 and 2, if necessary. For further potentiometer adjustment procedures, call or fax our service department and request document #09300072.

CHECKLIST

Before Turning Power On

1. Make sure that all connections are properly insulated.
2. Tuck wire to prevent interference with coin travel or coil armature movement.
3. Check the power cord for firm connection to the PC board.
4. Make sure the Comparitor is mounted securely in the equipment.
5. Check the entry chute alignment by inserting the proper coin. The coin should fall freely, without stopping, through the Comparitor and reject out of the equipment.

Turn Power On

1. The L.E.D. will light when voltage is applied.
2. Drop good coins. They should be recognized by the Comparitor and accepted.
3. Repeat step 2 several times to make certain the unit is functioning properly.

The Comparitor is now ready for operation.

If a problem exists, review all of the instructions. If you are unable to resolve a problem, call our service department for assistance.

DIMENSIONS



CC-16

